

LP3905-A3 Application Board Information

National Semiconductor
Application Note 1527
Graham Roxburgh
November 5, 2007



General Information

The evaluation board is a complete circuit allowing full operation of the LP3905 within the recommended application circuit. Each board is pre-assembled and tested in the factory. The board contains the LP3905-A3 in a 14 lead LLP package with all the associated passive components to enable all features of the device to be tested.

two 100mA linear regulators as configured on the board. The LP3905-A3 allows the two buck output voltages to be set by the user. This option is a variation on the LP3905 device which has 4 fixed output voltages. The LP3905 additionally features two enable pins allowing control over the device outputs.

LP3905 is optimized for low power handheld applications. This device provides two 600mA DC/DC Buck regulators, and

Schematic Diagram

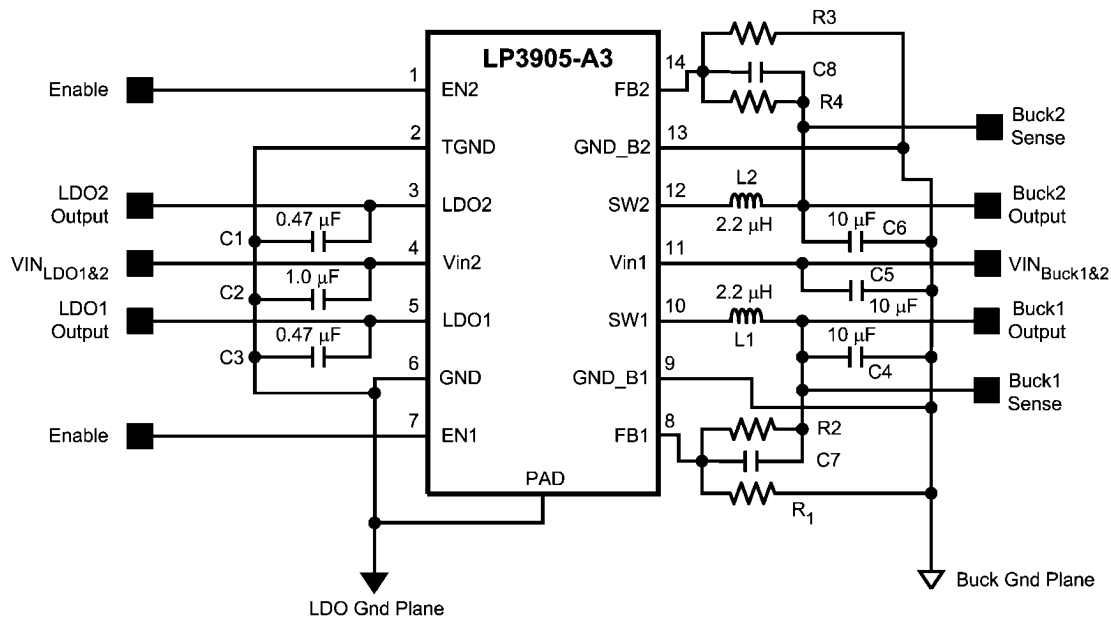

Evaluation Board Schematic

20209101

Operational Information

The circuit used in the evaluation board is shown above.

The LP3905-A3 evaluation board has the output voltages set as follows:

LP3905-A3 Output Voltages

O/P	Voltage (V)
Buck1	1.5
Buck2	1.85
LDO1	3.0
LDO2	2.8

The board is fitted with 0.47μF capacitors on the outputs of the LDO's and thus the load current for these LDO's should not exceed 100mA.

The device has 1MΩ internal resistors from EN1 and EN2 to GND.

Output Voltage Pre-set

For initial use the LP3905-A3 sample board has been pre-set to 1.5V and 1.85V. The outputs of these two regulators may be set via the selection of the external resistor network forming the output feedback between the output voltage side of the inductor and the feedback pins (FB1, FB2) of the device and the feedback pins and ground. The user should thus alter the values of R1, R2 and C7 to give the desired output voltage on Buck1 and R3, R4, and C8 to change the output voltage on Buck2.

Output Voltage Selection

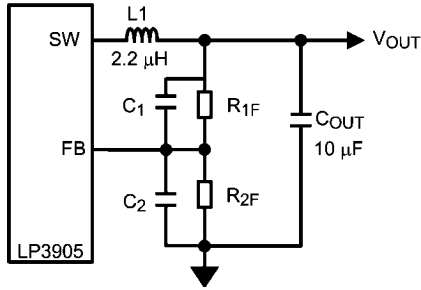

20209110
Adjustable Buck Components showing Resistor Feedback Network

The recommended resistance between FB and GND is around 200kΩ. At this level the current through the resistor

network is low but does not give rise to noise problems. The feedback node voltage is 0.5V and hence a 200kΩ resistor will result in a 2.5μA current.

The formula for output voltage selection is

$$V_{OUT} = V_{FB} \times \left(1 + \frac{R_{1F}}{R_{2F}}\right)$$

- 20209112
- V_{OUT} - output voltage (Volts)
 - V_{FB} - feedback voltage (0.5V)
 - R_{1F} - feedback resistor (V_{OUT} to FB)
 - R_{2F} - feedback resistor (FB to GND)

For any output voltage greater than or equal to 1.0V, a capacitor should be added across R_{1F} . The chosen value of the capacitor is governed by the formula

$$C_1 = \frac{1}{(2 \times \pi \times R_{1F} \times 45 \times 10^3)}$$

20209111
The value of this capacitor may be chosen from the following table giving the recommended component values for specified output voltages. C2 shown between the FB node and GND is only required at higher output voltages.

Recommended Component Values for Specified Output Voltages

V_{OUT} (V)	R_{1F} (kΩ)	R_{2F} (kΩ)	C1 (pF)	C2 (pF)
1.0	200	200	18	none
1.2	280	200	12	none
1.4	357	200	10	none
1.5	365	182	10	none
1.6	442	200	8.2	none
1.85	536	200	6.8	none
2.5	402	100	8.2	none
2.8	464	100	8.2	33
3.3	562	100	6.8	33

Connection Information

Connect a supply voltage (3.0V to 5.5V) to either of the VIN pins on the evaluation board. LK4 hardwired on the board connects both the BUCK supply side to the LDO supply side. These supplies are both required to correctly power the device.

Supply ground may be connected at either GND or BKGND. LK3 which is hardwired on the eval board connects the BUCK gnd to the LDO gnd.

For best results in current measurements on the Buck outputs, use 4 wire measurement techniques to eliminate any voltage drop on the PCB traces or connecting wires to the loads. For this the instrument sense connection should be connected to the corresponding buck 'S' (sense) connection on the evaluation board.

Input leads should be kept reasonably short to minimize inductance.

ON/OFF control is provided by logic signals on EN1 and EN2. A minimum of 1.2V is required on these pins to enable the corresponding outputs. The outputs will be shutdown with the enable pins set to 0.4V or less. If ON/OFF control is not required, then either or both enable pins may be connected to V_{IN} either externally or by using the on-board connection matrix.

A number of control options are provided on board by either hardwiring or using reconfigurable links on the 4-way matrix.

Link Matrix Details

Link	Link	Connection Description
1 - 2	3 - 4	EN1 and EN2 connect to VIN supply. All outputs power on with the supply voltage.
3 - 4	-	EN1 connects to EN2 and may be driven externally from one source to control all outputs.
1 - 2	-	EN1 connects to VIN. Buck1, LDO1, and LDO2 outputs are enabled at device power up. Buck 2 should be enabled separately using an external source connected to EN2.
1 - 3	-	EN2 connects to VIN. Buck 2 is enabled at device power up. Buck1, LDO1, and LDO2 outputs should be enabled using an external source connected to EN1.
-	-	Both EN1 and EN2 can be driven separately from external sources connected at the board inputs EN1 and EN2.

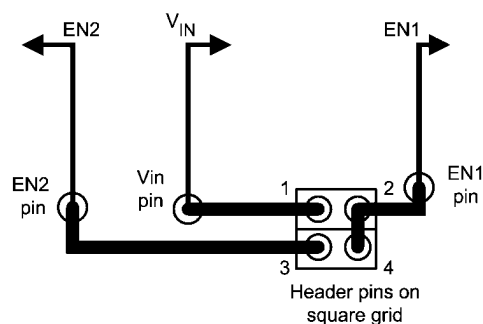

20209105

Link Matrix Diagram

PCB Layout

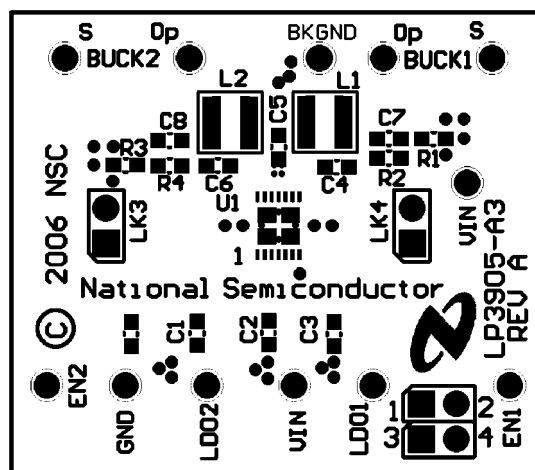

20209102

PCB Component and Pin Layout
Board Size 1.5" x 1.3"

Bill of Materials for LP3905-A3 LLP Evaluation Board

Item	Type	Value	Qty	Part Number Suggested	Manufacturer	Footprint
U1			1	LP3905-A3	NSC	SDA14B
L1,L2	Inductor	2.2 μ F	1	DO3314-222MLB*	Coilcraft	
C1, C3	Capacitor	0.47 μ F	2	GRM188R61A474KA61D*	Murata	0603
C4, C5, C6	Capacitor	10 μ F	3	GRM21BR61A106KE19L*	Murata	0805
C2	Capacitor	1.0nF	1	GRM188R61A105KA61D*	Murata	0603
C7	Capacitor	10pF	1	GRM1885C1H100JZ01B*	Murata	0603
C8	Capacitor	6.8pF	1	GRM1885C1H6R8DZ01B*	Murata	0603
R1	Resistor	182 Ω	1	CRCW06031823F*	Vishay	0603, 1%
R2	Resistor	365 Ω	1	CRCW06033653F*	Vishay	0603, 1%
R3	Resistor	200 Ω	1	CRCW06032003F*	Vishay	0603, 1%
R4	Resistor	536 Ω	1	CRCW06035363F*	Vishay	0603, 1%

* - or similar.

Notes

For more National Semiconductor product information and proven design tools, visit the following Web sites at:

Products		Design Support	
Amplifiers	www.national.com/amplifiers	WEBENCH	www.national.com/webench
Audio	www.national.com/audio	Analog University	www.national.com/AU
Clock Conditioners	www.national.com/timing	App Notes	www.national.com/appnotes
Data Converters	www.national.com/adc	Distributors	www.national.com/contacts
Displays	www.national.com/displays	Green Compliance	www.national.com/quality/green
Ethernet	www.national.com/ethernet	Packaging	www.national.com/packaging
Interface	www.national.com/interface	Quality and Reliability	www.national.com/quality
LVDS	www.national.com/lvds	Reference Designs	www.national.com/refdesigns
Power Management	www.national.com/power	Feedback	www.national.com/feedback
Switching Regulators	www.national.com/switchers		
LDOs	www.national.com/ldo		
LED Lighting	www.national.com/led		
PowerWise	www.national.com/powerwise		
Serial Digital Interface (SDI)	www.national.com/sdi		
Temperature Sensors	www.national.com/tempsensors		
Wireless (PLL/VCO)	www.national.com/wireless		

THE CONTENTS OF THIS DOCUMENT ARE PROVIDED IN CONNECTION WITH NATIONAL SEMICONDUCTOR CORPORATION ("NATIONAL") PRODUCTS. NATIONAL MAKES NO REPRESENTATIONS OR WARRANTIES WITH RESPECT TO THE ACCURACY OR COMPLETENESS OF THE CONTENTS OF THIS PUBLICATION AND RESERVES THE RIGHT TO MAKE CHANGES TO SPECIFICATIONS AND PRODUCT DESCRIPTIONS AT ANY TIME WITHOUT NOTICE. NO LICENSE, WHETHER EXPRESS, IMPLIED, ARISING BY ESTOPPEL OR OTHERWISE, TO ANY INTELLECTUAL PROPERTY RIGHTS IS GRANTED BY THIS DOCUMENT.

TESTING AND OTHER QUALITY CONTROLS ARE USED TO THE EXTENT NATIONAL DEEMS NECESSARY TO SUPPORT NATIONAL'S PRODUCT WARRANTY. EXCEPT WHERE MANDATED BY GOVERNMENT REQUIREMENTS, TESTING OF ALL PARAMETERS OF EACH PRODUCT IS NOT NECESSARILY PERFORMED. NATIONAL ASSUMES NO LIABILITY FOR APPLICATIONS ASSISTANCE OR BUYER PRODUCT DESIGN. BUYERS ARE RESPONSIBLE FOR THEIR PRODUCTS AND APPLICATIONS USING NATIONAL COMPONENTS. PRIOR TO USING OR DISTRIBUTING ANY PRODUCTS THAT INCLUDE NATIONAL COMPONENTS, BUYERS SHOULD PROVIDE ADEQUATE DESIGN, TESTING AND OPERATING SAFEGUARDS.

EXCEPT AS PROVIDED IN NATIONAL'S TERMS AND CONDITIONS OF SALE FOR SUCH PRODUCTS, NATIONAL ASSUMES NO LIABILITY WHATSOEVER, AND NATIONAL DISCLAIMS ANY EXPRESS OR IMPLIED WARRANTY RELATING TO THE SALE AND/OR USE OF NATIONAL PRODUCTS INCLUDING LIABILITY OR WARRANTIES RELATING TO FITNESS FOR A PARTICULAR PURPOSE, MERCHANTABILITY, OR INFRINGEMENT OF ANY PATENT, COPYRIGHT OR OTHER INTELLECTUAL PROPERTY RIGHT.

LIFE SUPPORT POLICY

NATIONAL'S PRODUCTS ARE NOT AUTHORIZED FOR USE AS CRITICAL COMPONENTS IN LIFE SUPPORT DEVICES OR SYSTEMS WITHOUT THE EXPRESS PRIOR WRITTEN APPROVAL OF THE CHIEF EXECUTIVE OFFICER AND GENERAL COUNSEL OF NATIONAL SEMICONDUCTOR CORPORATION. As used herein:

Life support devices or systems are devices which (a) are intended for surgical implant into the body, or (b) support or sustain life and whose failure to perform when properly used in accordance with instructions for use provided in the labeling can be reasonably expected to result in a significant injury to the user. A critical component is any component in a life support device or system whose failure to perform can be reasonably expected to cause the failure of the life support device or system or to affect its safety or effectiveness.

National Semiconductor and the National Semiconductor logo are registered trademarks of National Semiconductor Corporation. All other brand or product names may be trademarks or registered trademarks of their respective holders.

Copyright© 2007 National Semiconductor Corporation

For the most current product information visit us at www.national.com



National Semiconductor Americas Customer Support Center
 Email: new.feedback@nsc.com
 Tel: 1-800-272-9959

National Semiconductor Europe Customer Support Center
 Fax: +49 (0) 180-530-85-86
 Email: europe.support@nsc.com
 Deutsch Tel: +49 (0) 69 9508 6208
 English Tel: +49 (0) 870 24 0 2171
 Français Tel: +33 (0) 1 41 91 8790

National Semiconductor Asia Pacific Customer Support Center
 Email: ap.support@nsc.com

National Semiconductor Japan Customer Support Center
 Fax: 81-3-5639-7507
 Email: jpn.feedback@nsc.com
 Tel: 81-3-5639-7560